

MÜGRO MIX(K)+

Dynamic Foam Mixing System

Functional range of MÜGROMIX(K)+

- Display Systems
- Lamination Systems
- Tube Winding Systems
- Edge Protection Systems



Why foaming



The wish to save adhesive associates with the wish to reduce the water proportion in the adhesive. This would favour behind a reduction of the production costs also the curing time and the flatness.

With the today's coating systems it is often not possible to reduce the adhesive volume proportion and therefore the adhesive mass application to the necessary minimum. Older systems are still concerned frequently.

To reach this limit a filling compound have to be found which meets the above requests and which is also reasonably priced.

**Air represents an ideal
“filling compound”.**

With the MÜGROMIX(K)+ the air will be mixed product-protective through a dynamic low shear mixing head into the adhesive compound.

Therefore the coating system can applicate the same volume mass-reduced on the product which have to be applied.

Through the easy adjustment possibility of the foam weight on the MÜGROMIX(K)+ the adhesive proportion can easy be reduced to the needed minimum and therefore adapt to the product which have to be applied and the used adhesive.

Depending on the application case adhesive of 15-40% will be saved and the humidity content will be reduced up to 10% relative air humidity. Thereby the flatness will be improved, from which the successor processes (print, cut, punch) profits seriously.

By shortening of the curing time the drying costs can be reduced and/or the production speed can be increased.

With the MÜGROMIX(K)+ adhesives as PVA, PVAC, latex, water glass etc. can be foamed up. All well-known manufacturers of adhesives currently offers foamable adhesives.

Functional descriptions

- The MÜGROMIX(K)+ will be steered and controlled through a SIEMENS SPS of the 300er series.
- Production parameters can be easy and quick adjusted and checked.
- Modern sensors registers continuously the product- and air throughput and ensures therefore an exact foam weight.
- A connection to a superior process system is possible.

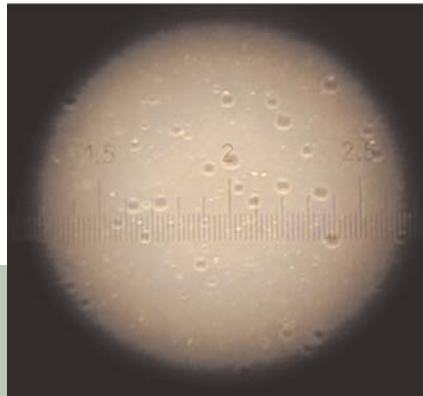
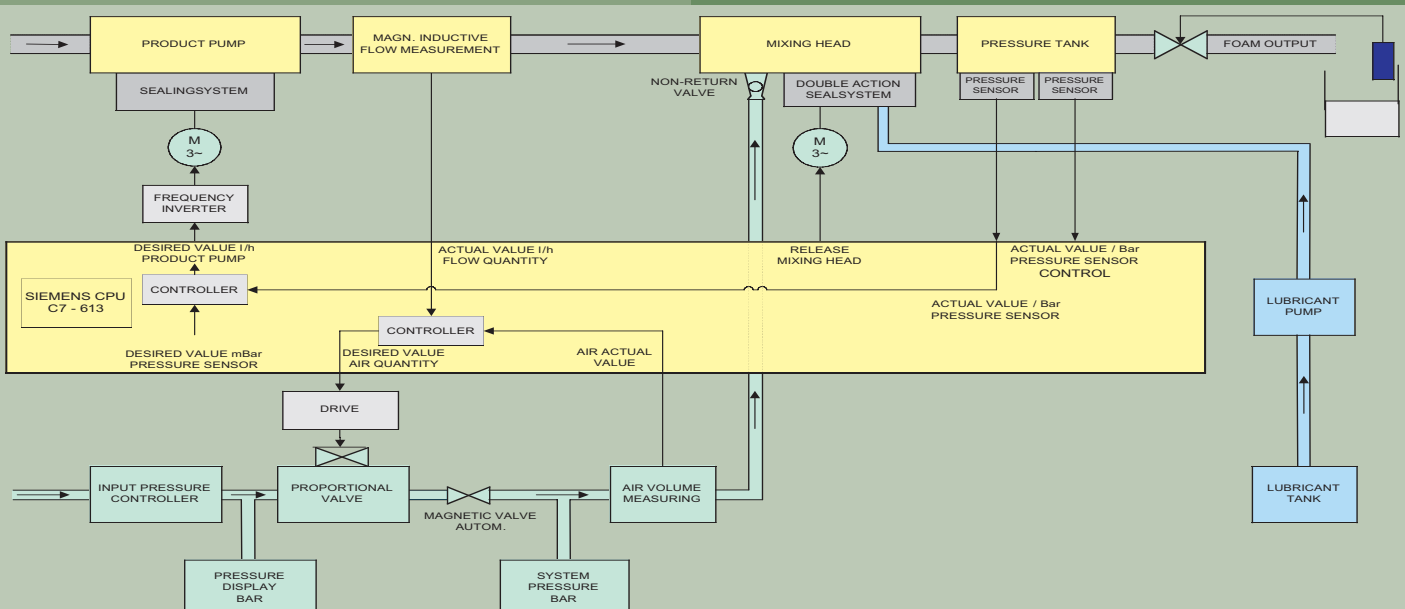

Photo macrograph:
PVAC-adhesive
20% air content
foam pore <math>< 80\mu\text{m}</math>

Integration

- The MÜGROMIX(K)+ can easy be integrated in the existing coating system.
- The currently used pump (piston-, diaphragm- or hose pump) will be replaced by the MÜGROMIX(K)+. The MÜGROMIX(K)+ use the existing level control of the coating system.
- The MÜGROMIX(K)+ adapts automatically to the delivered quantity. This ensures a continuous production, which favours the foam image seriously.
- The integrated foam store buffers delivery peaks, so that in combination with the high power reserves of the MÜGROMIX(K)+ a connection to several coating systems with one MÜGROMIX(K)+ is possible.

Function diagram



Technical data

• Product throughput *	max. 1000 kg/h	• Dimensions (L/W/H) **	1500/800/870 mm
• Product density *	1000 - 1300 g/l	• Air supply	400 V/50 Hz
• Product viscosity *	max. 4000 mPa*s	• Power supply **	max. 3,0 kW
• Foam density *	500 - 900 g/l		
• Mixing head speed	300 rpm		
• Air consumption	max. 1000 l/h		
• Weight **	about 350 kg		

* The data relates to the basic versions. Important here are the customer-related formulae.

** The data depends on the type of mixing head used and the number of additive or solid matter units.

Represented by:

Progress by technical innovation



MST Mischsystemtechnik Wolfgang Groth GmbH
Am Marienhof 8 · D-22880 Wedel
Telefon: +49 (4103) 800 11-3 · Fax: +49 (4103) 800 11-55
E-Mail: info@mst-groth.com · Internet: www.mst-groth.com