

MÜGROMIX +

Dynamic Foam Mixing System

Functional range of MÜGROMIX+

- Carpet industry
- Non-woven industry
- Paper industry
- Mattress industry
- Textile industry



Main Tasks

- Continuous foaming of liquids and low viscous pastes
- Product saving foaming by dynamic low-shear mixing heads



MÜGROMIX+ with axial mixing head type MÜ3

Advantages

- All components coming into contact with the product are made of stainless steel
- Easy to maintain housing:
Pumps and mixing heads are easily accessible
- Large selection of radial and axial mixing heads and blenders
- Fully automatic procedure as a result of using the most up-to-date process computers
- Low power consumption through use of modern gear motors
- Very quick air control (<300mS):
Stable foam weight regardless of product throughput changes or fluctuation in the air supply



Basic equipment

- Fully automatic foaming of a liquid or low-viscous paste with a gas.
High-quality measurement sensors together with a quick control engineering ensures a constant foam weight over the total working area.

- Dry-run protection of all product pumps and additive pumps
- A Siemens Step 7 compact CPU controls the process
- System speed synchronization



Mixing head seals
 - double acting lip seal
 - double acting stuffing box seal
 - double acting mechanical seal



Panel
 - easy to handle
 - all important system messages in view

Optional equipment

- Shaft seal for mixing head and pump alternatively stuffing box seal, double acting stuffing box seal, lip seal or double acting mechanical seal
- Passive or active cooling of the shaft seals
- Depending on the application several radial and axial mixing heads and blenders are available



Modular design in every detail

Functions diagram

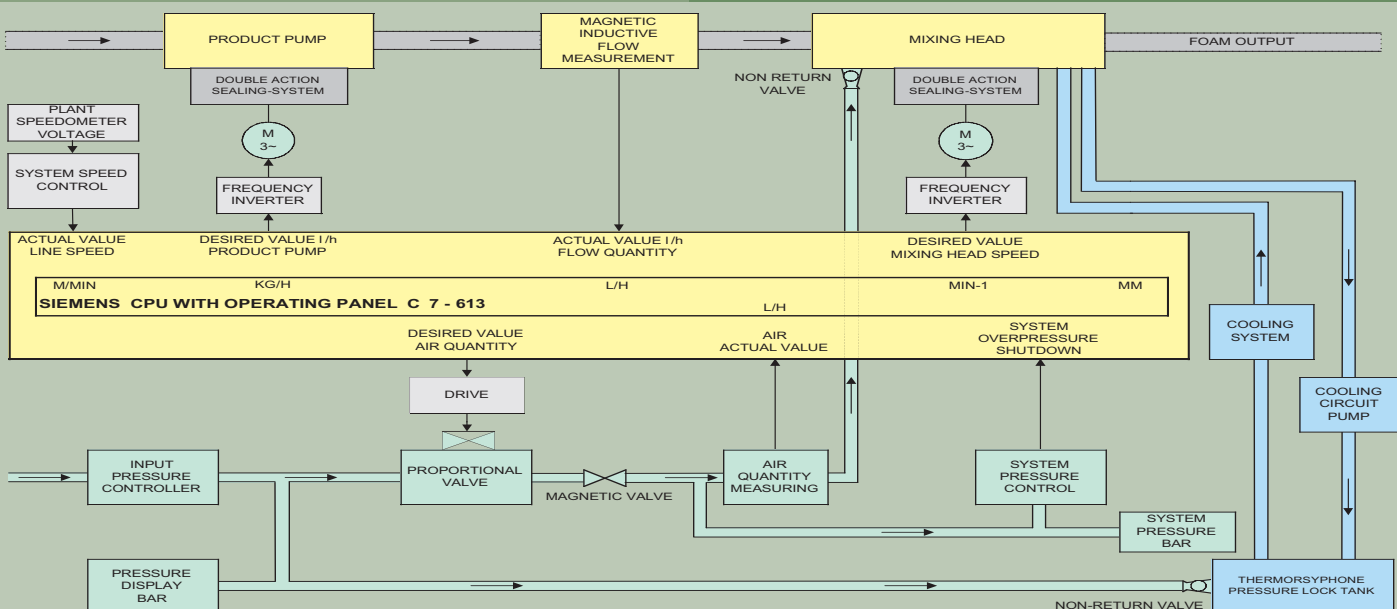

Technical data

• Product throughput *	10 - 100 l/h 20 - 200 l/h 60 - 600 l/h 120 - 1200 l/h	• Dimensions (L/W/H) Single head system **	2200/800/800 mm
• Product density *	Project-related in g/l	• Power supply	400 V/50 Hz
• Product viscosity *	max. 8000 mPa*s	• Power consumption **	1,7 – 3,5 kW
• Foam weight *	Project-related in g/l	• Mixing head types	
• Mixing head revolutions	50 - 300 rpm	MÜ1	radial, 258 Pins
• Air consumption	Project-related	MÜ2	radial, 427 Pins
• Weight **	350 - 650 kg	MÜ3a	axial, 594 Pins
		MÜ3c	axial, 1260 Pins
		MÜ3u (Blender)	axial, 396 Pins
		MÜ4	axial, 1404 Pins
		MÜ5	radial, 497 Pins
		MÜ6 (Three chamber sandwich)	radial, 1371 Pins

* The data relates to the standard versions. Other data is also possible on request.

** The data depends on the type of housing or mixing head used.

Represented by:

Progress by technical innovation

HEITEC Auerbach GmbH & Co.KG

Industriestrasse 26 · D-25469 Halstenbek

Telefon: +49 (4101) 81 928 -60 · Fax: +49 (4101) 81 928 -65

E-Mail: info@mst-heitec.de · Internet: www.mst-heitec.de